

Mikron

VCE Pro

600
800
800W
1000
1200
1400
1600
2000



Passion for Precision

GF Machining Solutions

When all you need is everything, it's good to know that there is one company that you can count on to deliver complete solutions and services. From unmatched Electrical Discharge Machining (EDM), Laser texturing, Laser micromachining, Additive Manufacturing and first-class Milling and Spindles to Tooling and Automation, all of our solutions are backed by unrivaled Customer Services and expert GF Machining Solutions training. Our AgieCharmilles, Microsolution, Mikron Mill, Liechti, Step-Tec and System 3R technologies help you raise your game—and our digital business solutions for intelligent manufacturing, offering embedded expertise and optimized production processes across all industries, increase your competitive edge.



+ We are Mikron Mill.
We are GF Machining Solutions.

Contents

4	Market segments and applications
6	Technology / Solutions
8	Robust and precise
10	Robot interface
13	Table
14	Tool Magazines
17	Cooling
18	Control
19	All about the Workpiece
20	Options

22	Technical Specifications
26	GF Machining Solutions

Ramp up your production of simple to complex molds, dies prototypes and single parts. Whether you're a job shop, mold and die maker, small to medium-sized operation, prototype manufacturer or producer of single parts, this reasonably priced bestseller delivers. Get a stiff machine base and high-tech key components—along with CNC, Spindle and accuracy-supporting linear scales included—to drive your success.

Market segments and applications

Typical applications

- + Meet your distinct applications needs, thanks to three different available Spindles.
- + Get a high-torque, 6,000 rpm Spindle or a highly dynamic 16,000 rpm Step-Tec Spindle.
- + Open new performance and quality horizons with this machine line, available in seven sizes.
- + Get the surface area to clamp all workpieces with machining capacity over the full travel range, whichever X travel you choose: 600-, 800-, 1000-, 1,200-, 1,600 or 2,000 mm.

Mold and die

Mold for biscuit packaging

- Al 99.5 aluminum
- Mold construction
- + Machined using HSC technology
- + Minimum quantity lubrication
- + The machine is highly dynamic, which reduces machining time considerably
- + Machining time including rough machining approx. 7 h
- + The tools are measured by laser



Automotive

Motor flange

- X38CrMoV 5 1
- High-alloy hot-working steel
- Mechanical engineering
- + Thread cutting without compensating chuck
- + The touch probe was used to automatically align machining on the back
- + Tools measured using the tool touch measuring system

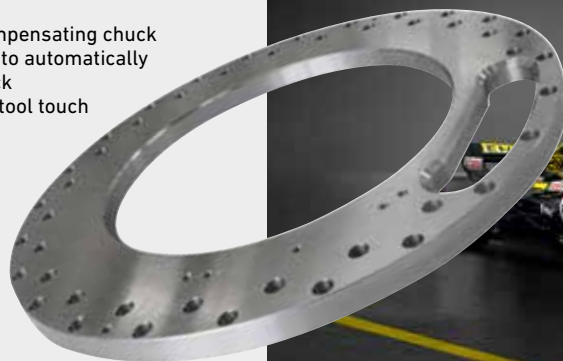

Machinery and general mechanics

Four-axis cutting drum

- 34CrAlMo5 nitrided steel
Paper industry
- + Cutting drum contours absolutely precise
 - + Programmed using the cylinder mantel milling function
 - + With a 0.5 ms block processing time, even complex contours can be executed quickly



Fixture

- Ck45
Mechanical engineering
- + High cutting performance
 - + Precision round-pocket milling
 - + Preset pocket milling cycles make programming on the machine quick and easy



Baseplate

- AlCu4Mg1.5
High-strength aluminum alloy
Electronics/mechatronics
- + High cutting speeds and small tool diameters require high spindle speeds
 - + High-quality surface
 - + Longer tool service life because tool is cooled

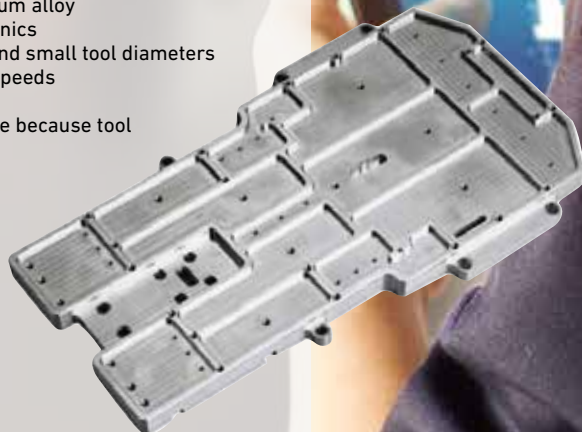

Technology

High-efficiency Milling

Get a stiff machine base and high-tech key components—along with CNC, Spindle and accuracy-supporting linear scales included—to drive your success.

Experience easy setup, excellent ergonomics, a choice of X travels from 600 to 2,000 mm. Position your business to machine a wide variety of materials and execute a vast variety of applications.

- + **Robust**
- + **Reliable**
- + **Ergonomic**
- + **Efficient**



**Efficiency
and
productivity**

Solutions

The right solution— for you

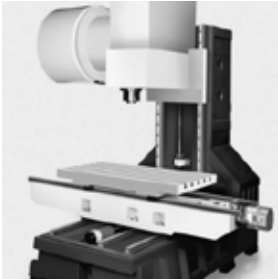

Highly stiff, robust, variable



From standard to special—
for you



Fast delivery for fast ROI



Low downtime due to quality
components

Customer benefits

- + Reliable, affordable three-axis solution.
- + Experience high-high volume, maximum load chip removal and minimal vibration. All while achieving top part quality.
- + Meet your distinct applications needs, thanks to three different available Spindles (high-torque or highly dynamic).
- + Highly versatile machine concept with vast selection of optional equipment.
- + Enjoy unmanned production—nights or weekends.



Monitor your production
uptime



Secure your machines
availability

Robust and precise

Mikron VCE Pro core components

- + **Belt-driven spindle 6,000 rpm, 10,000 rpm, Inline spindle 16,000 rpm**
always offer sufficient performance for any conventional machining processes.
- + **Tool changer with double-arm gripper**
for even shorter downtimes.
- + **Feed rate up to 40 m/min (X + Y)**
to achieve the level of dynamism.
- + **Optional linear scales**
ensures a constant level of precision for machining, even when temperatures fluctuate.
- + **Clean enclosure**
thanks to perfect chip management.
- + **Handles heavy and large row parts efficiently**
with on a smallest footprint.
- + **Robot interface**
for additional working hours at lowest cost.



VCE 600 Pro	500 mm
VCE 800 Pro	500 mm
VCE 800W Pro	560 mm
VCE 1000 Pro	560 mm
VCE 1200 Pro	600 mm
VCE 1400 Pro	650 mm
VCE 1600 Pro	900 mm
VCE 2000 Pro	900 mm



VCE 600 Pro	540 mm
VCE 800 Pro	540 mm
VCE 800W Pro	600 mm
VCE 1000 Pro	600 mm
VCE 1200 Pro	675 mm
VCE 1400 Pro	675 mm
VCE 1600 Pro	800 mm
VCE 2000 Pro	800 mm

VCE 600 Pro	600 mm
VCE 800 Pro	800 mm
VCE 800W Pro	860 mm
VCE 1000 Pro	1020 mm
VCE 1200 Pro	1200 mm
VCE 1400 Pro	1400 mm
VCE 1600 Pro	1600 mm
VCE 2000 Pro	2000 mm

Robot interface

Additional working hours at lowest cost

The well-established Mikron VCE pro series serves jobshoppers in all kind of segmentation. Customers are using the machine to produce prototypes but also for mid-size batches series production. The typical VCE pro customer is an contract manufacturer, he needs flexibility and reliability for his machine. While the performances of the machine in the market is well recognized, customers are looking for more and more independency and possibilities to run the machine as many hours as possible.

To cover this customer need GF will offer a Robot Interface option for the VCE Pro series. With this option, GF opens the possibility to connect the machine with an automation system either from S3R or from third party. VCE Pro milling machines, as well as any other technology can be now linked to a single automation cell, thus enabling autonomous collaborative production.

Step 1

**Upgrade the machine:
clamping with System 3R**

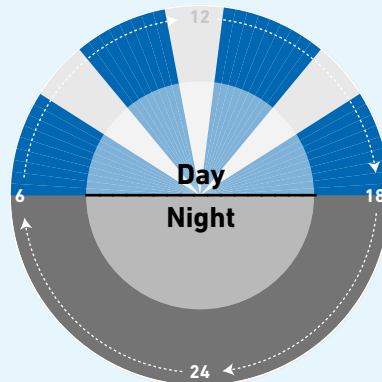

+20%
productivity

Step 2

**Extend your system:
pallet magazine and clamping
with System 3R**

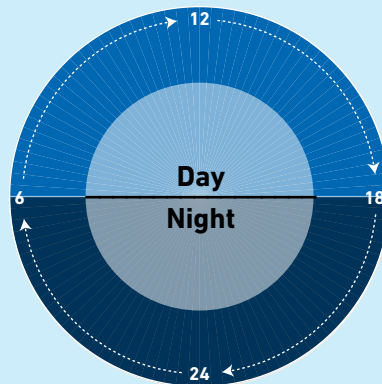

+16h
additional capacity
daily

**You'll run additional
shifts 24/7 at lowest
cost.**

- + Fast setup time
- + Lowest machine downtime
- + High profitability
- + Broad flexibility
- + Efficient productivity

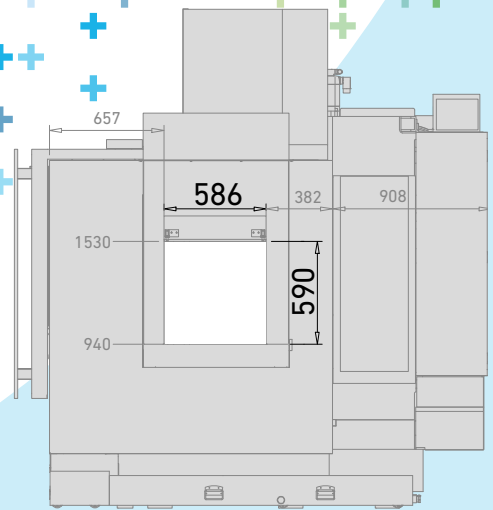

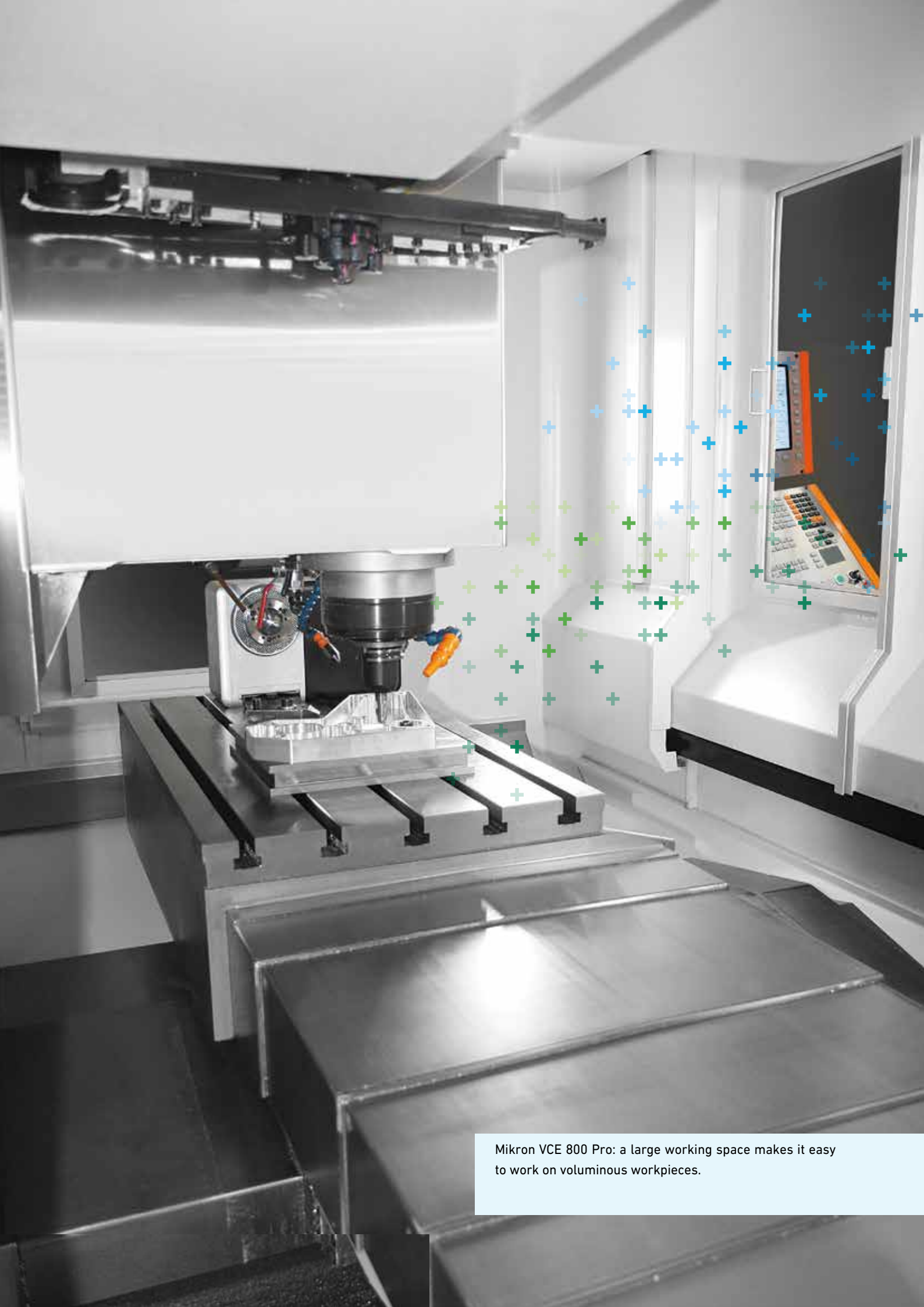

Mikron VCE 800 Pro: a large working space makes it easy to work on voluminous workpieces.

Table

There is still enough room for the clamping elements, even when travel ranges are used to the fullest



Extended usage possibilities thanks to fourth axis

A fourth axis connection is included in the Mikron VCE Pro's electrical cabinet as standard. This means it is easy to fit an indexer at any later stage. Activation is done using parameters at the controller. Many accessories are available.

The precision indexers belonging to the Mikron VCE Pro series are the right solution for machining medium to large workpieces. A small range of dependable products supplements the vertical machining center with a crucial fourth axis.

- + Pneumohydraulic axis clamp with integrated pressure intensifier
- + Center heights of 150 mm, 180 mm, 250 mm
- + Workpiece weights up to 1,000 kg



Compressed-air connection on every table

Each table is fitted with an air connector for pneumatically activated zero-point clamping systems.

Chips effectively flushed away

A side-mounted flushing system rinses the chips lying on the enclosure wall outlet directly into the chip conveyor. Spray and compressed-air pistols provide a flexible means of cleaning.



Tool Magazines

No restrictions on working space accessibility



- + Fast and reliable tool changer
- + Large door opening directly next to the tool changer and table
- + Tool magazine turned away from the working area

Customer benefits

- + No restricting objects in the working area -> Machining of cubic work pieces
- + Large working area
- + Tool changer is well protected against chips and cooling water
- + Tool holder taper protected
- + Loading tools during milling operation



More productivity with larger tool magazines



Tool lever

The machining autonomy of the popular VCE Pro line has been greatly increased.

Along with the 24-compartment and 30-compartment changers, chain changers with 40 and 60 compartments are now also available.

The 40- and 60-compartment chain changers are equipped with a simultaneous tool-fitting feature.

60
tool ports

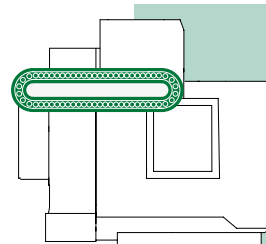

24 / 30
tool ports

40
tool ports

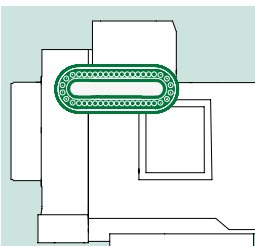
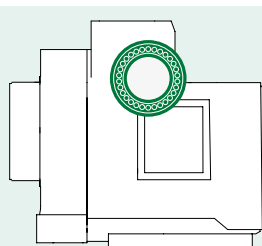

Tool Magazines	DT 24 (ISO 40)	DT 30 (ISO 40)	DT 24 (ISO 50)	CT 40 (HSK-A63)	CT 40 (ISO 40)	CT 40 (ISO 50)	CT 60 (ISO 40)
Machine types	VCE 600 Pro VCE 800 Pro VCE 800W Pro VCE 1000 Pro VCE 1200 Pro VCE 1400 Pro	VCE 1600 Pro VCE 2000 Pro	VCE 1600 Pro VCE 2000 Pro	VCE 600 Pro VCE 800 Pro VCE 800W Pro VCE 1000 Pro	VCE 600 Pro VCE 800 Pro VCE 800W Pro VCE 1000 Pro VCE 1200 Pro VCE 1400 Pro VCE 1600 Pro VCE 2000 Pro	VCE 1600 Pro VCE 2000 Pro	VCE 800W Pro VCE 1000 Pro VCE 1200 Pro VCE 1400 Pro
Tool magazine (type)	Double-arm, side-mounted	Double-arm, side-mounted	Double-arm, side-mounted	Double-arm, side-mounted	Double-arm, side-mounted	Double-arm, side-mounted	Double-arm, side-mounted
Number of tool ports	24	30	24	40	40	40	60
Tool selection	Bidirectional	Bidirectional	Bidirectional	Bidirectional	Bidirectional	Bidirectional	Bidirectional
Maximum tool diameter (mm)	77	85	125	75	75	125	75
With permanent space coding and with free neighboring spaces (mm)	115	150	240	125	125	240	125
Maximum tool length (mm)	305	305	350	305	305	350	305
Maximum tool weight (kg)	6	6	15	7	7	15	7
Tool-changing time "Chip to chip" (sec.)*	8	8	11	8	8	11	8
*) As per VDI Guideline 2852, Sheet 1							



There are no limits to how the Mikron VCE Pro machines can be used. This one is being used in die and mold construction for smoothing using a round-head cutter. Because the Mikron VCE Pro spindle can rotate at 16,000 rpm, the necessary cutting speeds can even be achieved using small tools.

Cooling

Spectacular performance in high efficiency milling

Programmed precision

Gone are the days of time-consuming and imprecise manual adjustments on the coolant inlet. A programmable coolant nozzle directs the jet automatically to precisely where the action is after each tool change (optional).



All-around cooling with spray ring

Cooling is always guaranteed with the optional spray ring (optional).



Cooling through the spindle, 18 or 42 bar

Coolant is fed directly to the cutting edges under high pressure and through the working spindle. The benefits of this are high cutting speeds, easy deep drilling, blind hole milling, and longer tool service life (optional). The supply unit consists of a large, mobile coolant tank and can be added to with an optionally available belt filter. This system has two switchable filter cartridges to enable uninterrupted use in production.

- + Cooled spindle head
- + Large coolant tank that can be pulled out on wheels, making cleaning easier
- + Spray gun and air gun
- + Coolant nozzles and blow-off nozzles on the spindle head

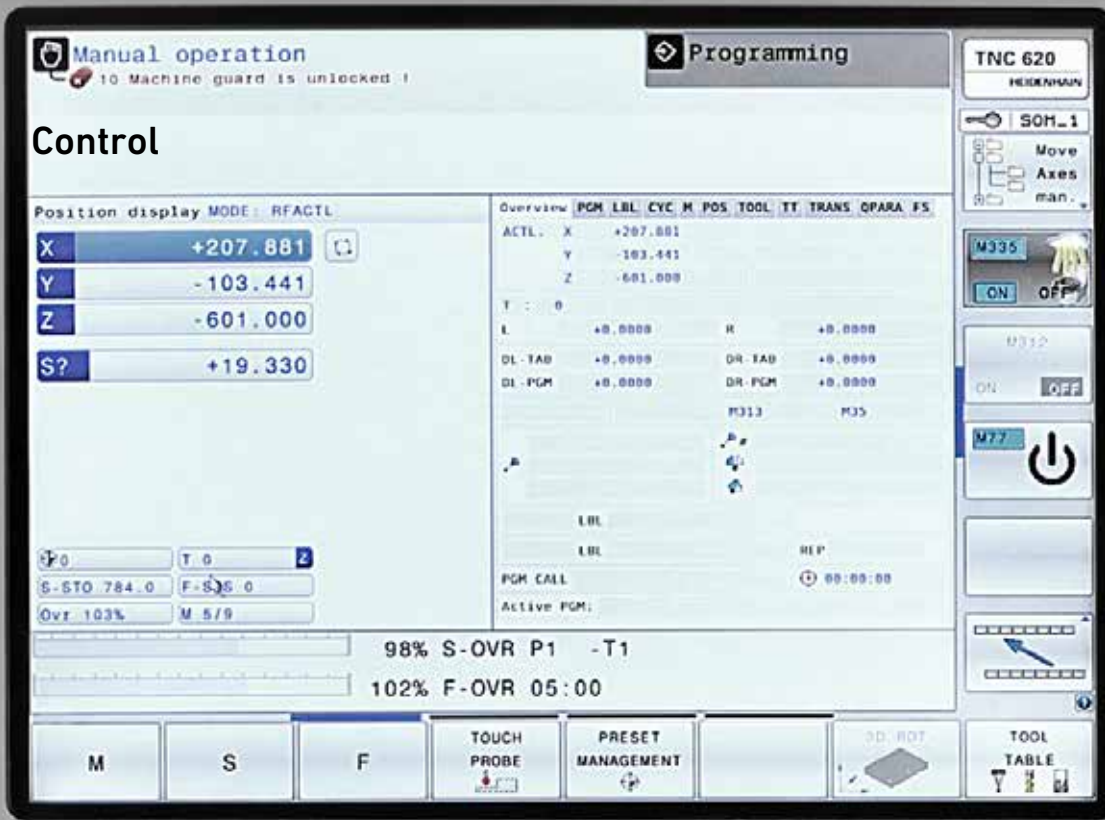

Ideal for any production job in the workshop

This control console does everything

Its clearly structured monitoring desk is genuinely user friendly. Fourteen function keys give you direct access to menu functions on, beneath and next to the 15-inch color TFT display. The console pivots and can be adjusted in height, and its screen tilts so you can avoid reflections.

Digital drive technology

A digital control circuit for the drive motors offers exceptionally dynamic control. This enables precision contour reproduction and excellent service quality.

Automatic calculation of cutting data

The control software offers a facility for automatically calculating cutting data. To do this, you enter tool-specific data into a table, from which the controller calculates suggested spindle speeds and feed rates, which technicians can of course then change and adjust to the levels they have found most effective.

- + Programming using Heidenhain plain text dialogue or DIN/ISO
- + Keyboard with alpha keys, track function keys, operating mode keys, and separate spindle and feed override potentiometers
- + Graphical support for the programming of cycles and contours, graphics for testing programs and for checking on current workpiece machining
- + Cutting data automatically calculated
- + Heat exchanger on electrical cabinet cools power components and keeps outside dust away from the cabinet by means of two separate circuits
- + Touch measuring system cycles
- + Short block processing time (1.5 ms)

All about the Workpiece

Efficient working preparation for shorter downtimes

The unusual design of this protective enclosure helps operators to make the important preparations for their work. They can also rely on our popular workpiece and tool measurement options. The Mikron VCE Pro helps you perform basic handling with ease so that you can focus on what is most important.

Outstanding view of the workpiece from three sides

An excellent window construction on both sliding doors at the front, along with big windows on either side, provides you with an unrestricted view of the setup and machining processes in a completely closed protective enclosure. Another benefit is that the working space is accessible from the side, with operating buttons for the tool magazine (optional).

Setting up is easy with the OMP 40-2 workpiece probe

An infrared probe inserted into the spindle enables the workpiece to be set up, detected, and measured rationally (optional).

This reduces setup times considerably.



Produce safely with the TS 27 tool probe

Precision tool setup, reliable tool breakage monitoring: the length and diameter of tools can be measured precisely using a probe mounted on the worktable (optional).

Tool measurement using laser

Tools with small diameters are measured by laser. Contours, such as those of round-head cutters, can also be monitored. The unit has a built-in blow-off nozzle in order to blow dirt off the tool before measuring (optional).



Options

Multiple options to drive your success



Tool touch measuring system TS 27



Laser tool measuring device



Preparing setup probe OMP 40-2



Setup probe OMP 40-2



Basic supply unit for IKZ (internal coolant supply), 18 bar



Supply unit for IKZ, 18 or 42 bar



Belt filter unit on cooling water tank

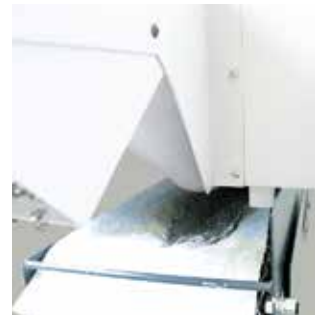

Integrated belt filter for sizes 600-1000



Spray ring



Programmable coolant nozzle



Minimum quantity lubrication



Mechanical oil/coolant separator



Indexer



Spindle cooling system water/water

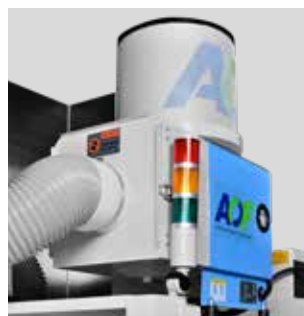

Powerfull mist extraction unit for VCE Pro 1600-2000

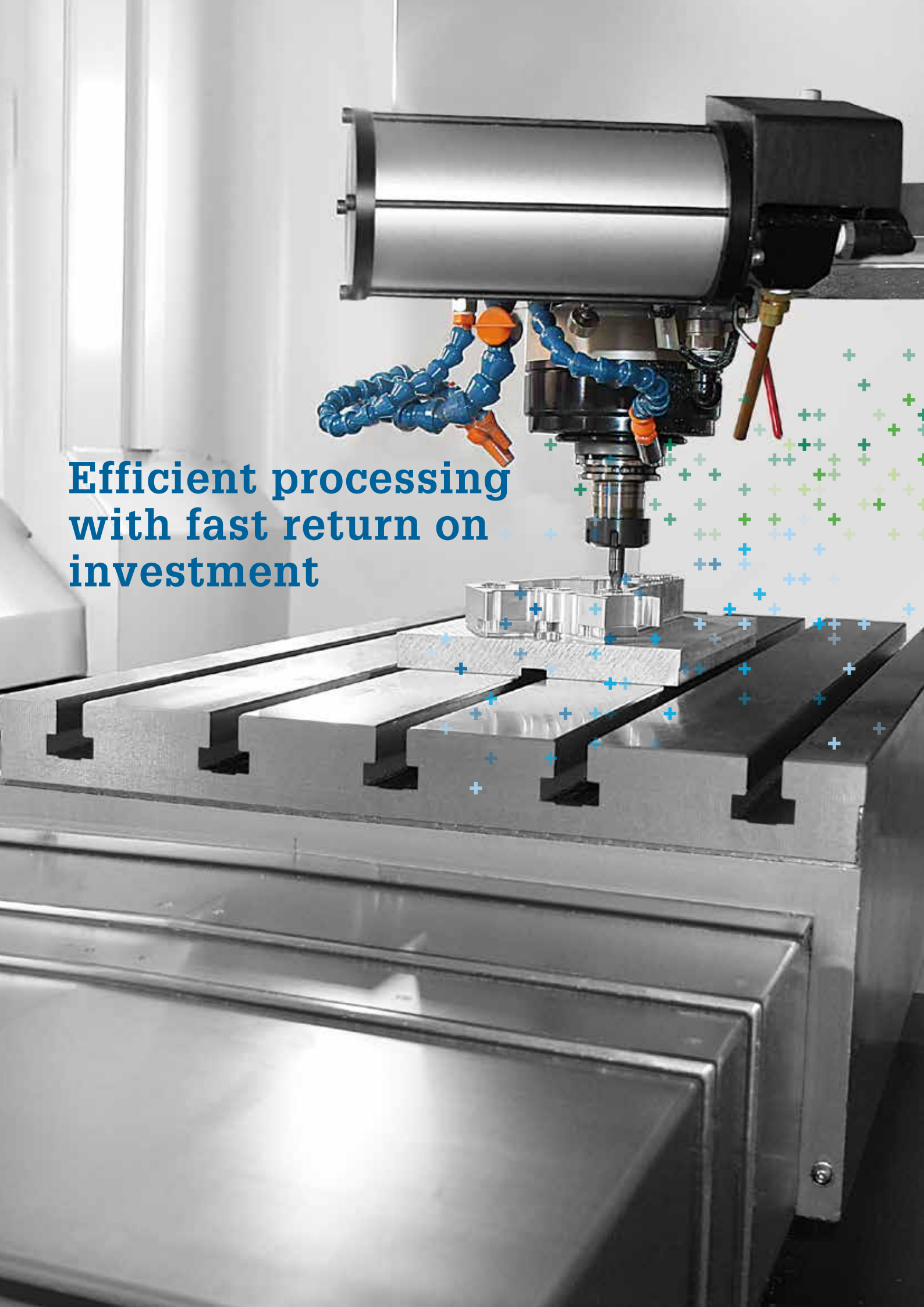

**Efficient processing
with fast return on
investment**

Technical data



Mikron VCE 600 Pro



Mikron VCE 800 Pro

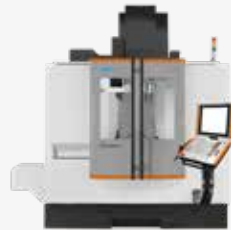

Mikron VCE 800W Pro

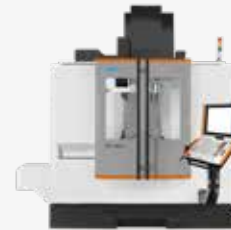

Mikron VCE 1000 Pro

			Mikron VCE 600 Pro	Mikron VCE 800 Pro	Mikron VCE 800W Pro
Travel ranges					
Longitudinal	X	mm	600	800	860
Transverse	Y	mm	500	500	560
Vertical	Z	mm	540	540	600
Max. distance between spindle tip and worktable		mm	690	690	735
Tool spindle					
Maximum speed up to		rpm	10'000 belt drive	10'000 belt drive	10'000 belt drive
Tool 40% duty cycle/S6		kW @ rpm	18,5 @ 1188	18,5 @ 1188	18,5 @ 1188
Spindle torque 40% duty cycle/S6		Nm	149	149	149
Tool mount			ISO-B40	ISO-B40	ISO-B40
Optional working spindle		rpm	16'000 inline	16'000 inline	16'000 inline
Tool mount			ISO-B40/HSK-A63	ISO-B40/HSK-A63	ISO-B40/HSK-A63
Travel speed					
Rapid traverse	X, Y	m/min.	40	40	40
Rapid traverse	Z	m/min	40	40	40
Tool magazine					
Magazine spaces		quantity	24/40 ISO-B40 24/40 HSK-A63 -	24/40 ISO-B40 24/40 HSK-A63 -	24/40/60 ISO-B40 24/40/60 HSK-A63 -
Tool magazine			Side-mounted	Side-mounted	Side-mounted
Max. tool length		mm	305	305	305
Max. tool diameter		mm	77/115	77/115	77/115
Worktable					
Table area		mm	700 x 500	910 x 500	1000 x 560
Maximum table load		kg	800	1100	1350
Number of T-grooves			5	5	5
T-groove spacing		mm	100	100	100
T-groove dimensions		mm	18 ^{+0.006/ +0.024}	18 ^{+0.006/ +0.024}	18 ^{+0.006/ +0.024}
Cooling					
Coolant tank capacity		l	300	300	300
Controller					
		Type	Heidenhain TNC 620	Heidenhain TNC 620	Heidenhain TNC 620
Machine weight					
		kg	4'800	5'000	6'500



Mikron VCE 1200 Pro

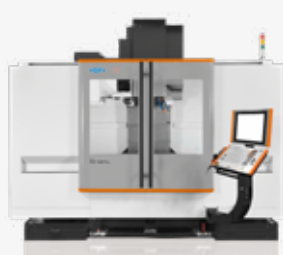

Mikron VCE 1400 Pro

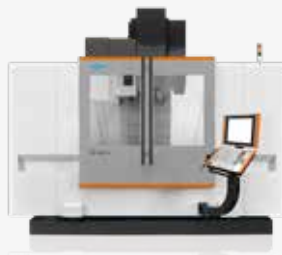

Mikron VCE 1600 Pro



Mikron VCE 2000 Pro

Mikron VCE 1000 Pro	Mikron VCE 1200 Pro	Mikron VCE 1400 Pro	Mikron VCE 1600 Pro	Mikron VCE 2000 Pro
1020	1200	1400	1600	2000
560	600	650	900	900
600	675	675	800	800
735	775	775	900	900
10'000 belt drive	10'000 belt drive	10'000 belt drive	10'000/6'000 belt drive	10'000/6'000 belt drive
18,5 @ 1188	18 @ 823	18 @ 823	18 @ 823	18 @ 823
149	209	209	209/350	209/350
ISO-B40	ISO-B40	ISO-B40	ISO-B40 / ISO-B50	ISO-B40 / ISO-B50
16'000 inline	16'000 inline	16'000 inline	16'000 inline	16'000 inline
ISO-B40 / HSK-A63	ISO-B40 / HSK-A63	ISO-B40 / HSK-A63	ISO 50, 350 Nm	ISO 50, 350 Nm
40	32	32	24	20
40	24	24	20	20
24/40/60 ISO-B40 24/40/60 HSK-A63 -	24/40/60 ISO-B40 24/40/60 HSK-A63 -	24/40/60 ISO-B40 24/40/60 HSK-A63 -	30/40/60 ISO-B40 24/40 ISO-B50 40/60 HSK-A63	30/40/60 ISO-B40 24/40 ISO-B50 40/60 HSK-A63
Side-mounted	Side-mounted	Side-mounted	Side-mounted	Side-mounted
305	305	305	305 (350, ISO-B50)	305 (350, ISO-B50)
77/115	77/115	77/115	85/150 (125/240, ISO-B50)	85/150 (125/240, ISO-B50)
1000 x 560	1220 x 620	1400 x 620	1700 x 850	2100 x 850
1350	1700	1700	2000	3000
5	5	5	7	7
100	100	100	100	100
18 ^{+0.006/ +0.024}	18 ^{+0.006/ +0.024}	18 ^{+0.006/ +0.024}	18 ^{+0.006/ +0.024}	18 ^{+0.006/ +0.024}
300	380	380	540	668
Heidenhain TNC 620	Heidenhain TNC 620	Heidenhain TNC 620	Heidenhain TNC 620	Heidenhain TNC 620
6'500	8'000	8'700	18'600	20'600

Mikron VCE 600 Pro X Y Z
 600 / 500 / 540
Mikron VCE 800 Pro 800 / 500 / 540

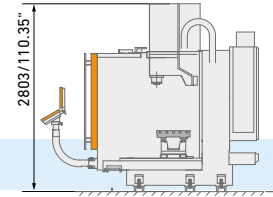
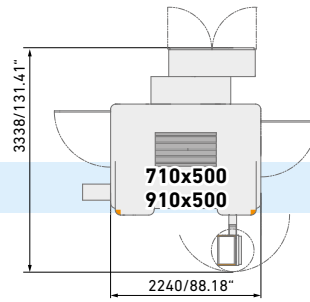

Mikron VCE 800W Pro X Y Z
 860 / 560 / 600
Mikron VCE 1000 Pro 1020 / 560 / 600

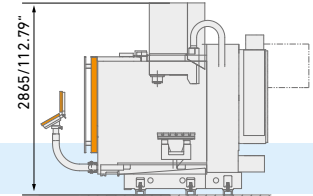
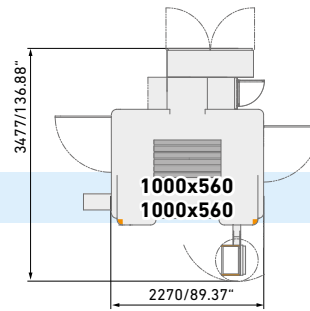

Mikron VCE 1200 Pro X Y Z
 1200 / 600 / 675
Mikron VCE 1400 Pro 1400 / 650 / 675

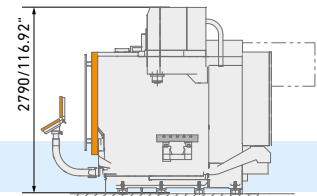
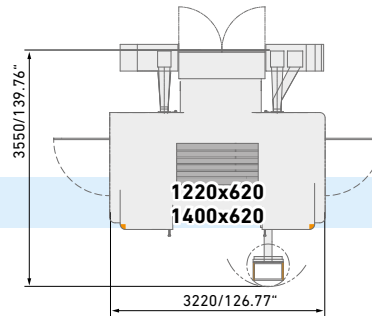

Mikron VCE 1600 Pro X Y Z
 1600 / 900 / 800

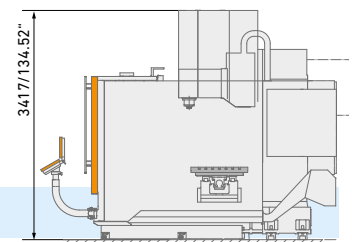
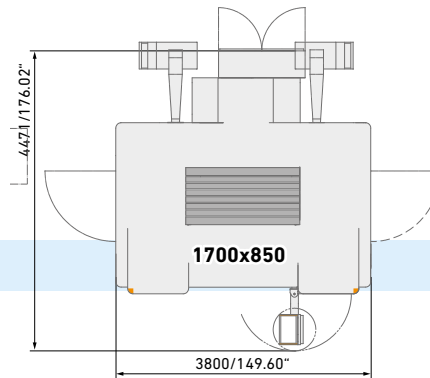

Mikron VCE 2000 Pro X Y Z
 2000 / 900 / 800

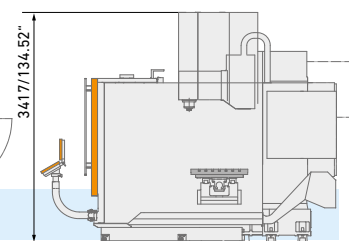
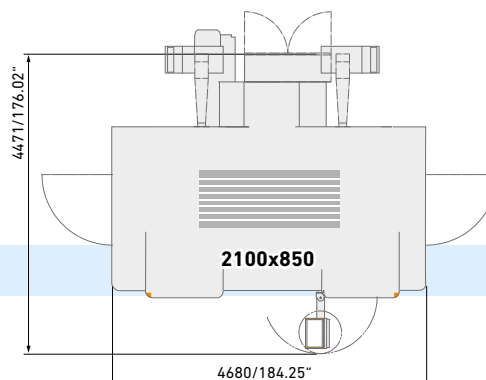

Standard equipment for all Mikron VCE 600 Pro to VCE 2000 Pro vertical machining centers

- + Protective enclosure
- + Two side windows, large front doors
- + Powerful fluorescent lights in the working space
- + Telescopic covers on X-, Y-, and Z-axis
- + Spiral chip conveyor with mechanical double filter
- + Automatic central lubrication
- + Side-mounted tool changer
- + Spray gun
- + Compressed-air gun
- + Operating status display
- + Working spindle 10,000 rpm
- + Spindle head cooled using cooling water
- + Regulated cooling for main spindle
- + Side-mounted flushing system
(Mikron VCE 600 Pro to Mikron VCE 1400 Pro)
- + Coolant nozzles and air nozzles on spindle head
- + Roll out coolant tank
- + Thread cutting without compensating chuck
- + Heidenhain TNC 620 track controller
- + USB 3.0 port
- + Compatible with optional extras
- + Ethernet port
- + Mobile handwheel
- + Additional protective screen

Accessories for all vertical machining centers

Mikron VCE 600 Pro to 2000 Pro

- + Cooling through spindle (IKZ), 18 or 42 bar
- + Belt filter unit to IKZ
- + Regulated cooling for main spindle
(6,000/10,000/16,000 rpm)
- + Compatible with fourth axis
- + NC indexer as fourth axis
- + Spray ring to spindle
- + Controllable coolant nozzle
- + Spray mist extraction
- + Infrared measurement and setup probe, type OMP 40-2
- + Tool touch measuring system type TS27
- + Integrated belt filter
- + BT tool version
- + Mechanical oil/coolant separator
- + Chip trolley
- + Minimum quantity lubrication
- + Compatible with angled head
- + Additional protective screen

Cutting data for CK 45 1.1191 (approx. 800 N/mm²)

		Mikron VCE 600 Pro to VCE 1000 Pro	Mikron VCE 1200 Pro to VCE 2000 Pro
Milling:			
HM blade head / five blades			
		10'000 rpm	10'000 rpm
HM tool		Flat-face mill 45°	Flat-face mill 45°
Tool diameter	mm	63	63
Cutting speed	m/min.	160	160
Speed	rpm	809	809
Feed rate	mm/min.	809	809
Plunging depth	mm	5,5	6
Plunging width	mm	63	63
Chip volume	cm ³ /min.	281	305
Spindle load	%	120	120
Drilling:			
Insert drill / two blades/ Ø 38 mm			
		10'000 rpm	10'000 rpm
Cutting speed	m/min.	220	220
Speed	rpm	1843	1843
Feed rate	mm/min.	221	221
Spindle load	%	80	65
Thread cutting:			
HSS tap / M24			
		10'000 rpm	10'000 rpm
Cutting speed	m/min.	10	10
Speed	rpm	133	133
Feed rate	mm/min.	398	398
Plunge depth	mm	36	36
Spindle load	%	45	40

About GF Machining Solutions

Multi-technology solutions provider

Our commitment to you and your specific applications is proven by the value-adding intelligence, productivity and quality delivered by our multi-technology solutions. Your success is our chief motivator. That's why we are continuously advancing our legendary technical expertise. Wherever you are, whatever your market segment and whatever the size of your operation, we have the complete solutions and the customer-centric commitment to accelerate your success—today.

EDM (electrical discharge machining)



Wire-cutting EDM

GF Machining Solutions' wire-cutting EDM is fast, precise and increasingly energy efficient. From ultraprecise machining of miniaturized components down to 0.02 mm to powerful solutions for demanding high-speed machining with respect to surface accuracy, our wire EDM solutions position you for success.

Die-sinking EDM

GF Machining Solutions is revolutionizing die-sinking EDM with features like iGAP technology to dramatically boost machining speed and reduce electrode wear. All of our die-sinking systems offer fast removal and deliver mirror finishes of Ra 0.1 µm (4 µin).

Hole-drilling EDM

GF Machining Solutions' robust hole-drilling EDM solutions enable you to drill holes in electrically conductive materials at a very high speed—and, with a five-axis configuration, at any angle on a workpiece with an inclined surface.

Milling



Milling

Precision tool and mold manufacturers enjoy a competitive edge with our Mikron MILL S solutions' fast and precise machining. The Mikron MILL P machines achieve above-average productivity thanks to their high performance and Automation. Customers seeking fastest return on investment benefit from the affordable efficiency of our MILL E solutions.

High Performance Airfoil Machining

Our Liechti turnkey solutions enable the highly dynamic manufacturing of precision airfoils. Thanks to their unique performance and our expertise in airfoil machining, you increase productivity by producing at the lowest cost per part.

Spindles

As part of GF Machining Solutions, Step-Tec is engaged in the very first stage of each machining center development project. Compact design combined with excellent thermal and geometric repeatability ensure the perfect integration of this core component into the machine tool.

Advanced manufacturing



Laser texturing

Aesthetic and functional texturing is easy and infinitely repeatable with our digitized Laser technology. Even complex 3D geometries, including precision parts, are textured, engraved, microstructured, marked and labeled.

Laser micromachining

GF Machining Solutions offers the industry's most complete line of Laser micromachining platforms optimized for small, high-precision features to meet the increasing need for smaller, smarter parts to support today's leading-edge products.

Laser Additive Manufacturing (AM)

GF Machining Solutions and 3D Systems, a leading global provider of additive manufacturing solutions and the pioneer of 3D printing, have partnered to introduce new metal 3D printing solutions that enable manufacturers to produce complex metal parts more efficiently.

Tooling and Automation



Tooling

Our customers experience complete autonomy while maintaining extreme accuracy, thanks to our highly accurate System 3R reference systems for holding and positioning electrodes and work pieces. All types of machines can easily be linked, which reduces set-up times and enables a seamless transfer of workpieces between different operations.

Automation

Together with System 3R, we also provide scalable and cost-effective Automation solutions for simple, single machine cells or complex, multi-process cells, tailored to your needs.

Software



Digitalization solutions

To drive its digital transformation, GF Machining Solutions acquired symmedia GmbH, a company specialized in software for machine connectivity. Together, we offer a complete range of Industry 4.0 solutions across all industries. The future requires the ability to adapt quickly to continual digital processes. Our intelligent manufacturing offers embedded expertise, optimized production processes, and workshop Automation: solutions for smart and connected machines.

Customer Services



Worldwide for you

Ensuring the best performance throughout the lifetime of our customers' equipment is the goal of our three levels of support. Operations Support offers the complete range of original wear parts and certified consumables. Machine Support includes spare parts, technical support, and a range of preventive services to maximize machine uptime. Business Support offers customer-specific business solutions.



Switzerland

Biel/Bienne
Losone
Geneva
Flawil
Langnau

www.gfms.com
www.gfms.com/ch

Europe

Germany, Schorndorf
www.gfms.com/de

United Kingdom, Coventry
www.gfms.com/uk

Italy, Agrate Brianza - MI
www.gfms.com/it

Spain, Sant Boi de Llobregat
Barcelona
www.gfms.com/es

France, Palaiseau
www.gfms.com/fr

Poland, Raszyn / Warsaw
www.gfms.com/pl

Czech Republic, Brno
www.gfms.com/cz

Sweden, Vällingby
www.gfms.com/system3r

Turkey, Istanbul
www.gfms.com/tr

Americas

USA
Lincolnshire, IL
Chicago, IL
Holliston, MA
Huntersville, NC
Irvine, CA
Woodridge, IL
www.gfms.com/us

Canada, Mississauga ON
www.gfms.com/us

Mexico, Monterrey NL
www.gfms.com/us

Brazil, São Paulo
www.gfms.com/br

Asia

China
Beijing, Shanghai, Chengdu, Dongguan,
Hongkong, Changzhou
www.gfms.com/cn

India, Bangalore
www.gfms.com/sg

Japan
Tokyo, Yokohama
www.gfms.com/jp

Korea, Seoul
www.gfms.com/kr

Malaysia, Petaling Jaya
www.gfms.com/sg

Singapore, Singapore
www.gfms.com/sg

Taiwan
Taipei, Taichung
www.gfms.com/tw

Vietnam, Hanoi
www.gfms.com/sg

At a glance

We enable our customers to run their businesses efficiently and effectively by offering innovative Milling, EDM, Laser, Additive Manufacturing, Spindle, Tooling and Automation solutions. A comprehensive package of Customer Services completes our proposition.

www.gfms.com

